

Measurement Scale of Student Participation in Community Volunteerism

Mohd Yusri Ibrahim

Centre for Fundamental & Liberal Education, University Malaysia Terengganu, Terengganu, Malaysia

Abstract

University students are important personal in making, they are the citizens who will contribute to the well-being of a community. Therefore, students need to be more responsible, care caring and participate involved in community activities. However, nowadays students were found to be less involved in volunteerism, especially at the community level. In order to solve the problem, we need to identify the indicators need to be identified in order to measure the participation behaviours, and acting further steps actions can be taken to improve their engagement. This study was conducted to develop a scale to measure the participation among university students, and testing the validation of the measurement. Conceptualizing of this study was suggested There are 10 indicators for the conceptualization of this study to measure the variable of participation in community volunteerism. This cross-sectional survey by using questionnaires was applied distributed inon the east side of peninsular of Malaysia for to 150 respondents, and analyzed by the structural equation modelling (SEM) by AMOS. The suggested indicators were considered accepted as the measurement elements by observing on the regression weight for standard loading, average variance extracted (AVE) for convergent validity, square root of AVE for discriminant validity, composite reliability (CR) for reliability of items, and at least three fit indexes for model fitness. Finally, a measurement scale of volunteerism participation for students was successfully developed, and suitable to be used in areas of research, evaluation, training, campaign or any type of programme in order to improve students' engagement with in community activities.

Keywords: Community participation; Community volunteerism; Youth.



CC BY: [Creative Commons Attribution License 4.0](https://creativecommons.org/licenses/by/4.0/)

1. Introduction

Youth is defined as young people aged between 15 to 24 years old (Ho *et al.*, 2015; UNESCO, 2012; Weinstock *et al.*, 2004). However, in the context of Malaysia, the National Youth Development Policy 1997 defines youth as a population aged from 15 to 40 years. In a country, youth form the majority in the composition of the population and its position is quite important in the context of national development (Haslinda *et al.*, 2012). From the social aspect, the Malaysian government has recognized youths as the future leaders for the well-being of the nation and society. The nation's future will be put forward by youths today. If the quality of youth is positive, the future of a country is bright. In Malaysia, most students of higher educational institutions are youths. Discussion on student behaviour is identical to discussion of youths.

In addition, youth are also seen as an important source or human capital to sustain the country's continued development and growth to drive the nation forward and become a developed nation by 2020 and achieve the target of the National Transformation 2050, as youths are the country's drivers in the future. The youths are the backbones of the future to rule the state (Sarimah, 2014), high hopes are placed on the shoulders of the youths by leaders and societies, so they should become more responsible, confident, credible, active and competent in various aspects. All these features are important preparations that youth need to build quality human capital and valuable assets to contribute to the well-being of communities, and nations.

As young people are physically fit, mind-conscious and more open-minded, the youth need to be sensitive, caring and engaging in community life. Youth should involve themselves in a range of community activities at the community level, in particular the participation in livelihood and neighbourhood activities. Youth involvement in volunteerism has become an increasingly important issue in facing the development and challenges of individual and community well-being (Ezhar and Madiha, 2015). Youth should actively engage in social work at the community level by joining collaborative activities to clean up the neighbourhood area, help community that face disasters, help in funerals, join religious activities at mosques and others, joining safety guides and so on. It is even better if the volunteerism activities in the community are pioneered by youths, with little guidance by elders and experienced community members.

Despite being urged to actively engage in social work and volunteerism, studies (Ezhar and Madiha, 2015; Haslinda *et al.*, 2012; Sarimah, 2014; Warren *et al.*, 2014) show that youth involvement in the community activities were still at an unsatisfactory level, with a declining trend in the youth engagement. This situation is somewhat worrisome, and is seen as contrary to the aspirations to be achieved through Vision 2020 and the National Transformation 2050. The aspirations are to form a developed society by maintaining a pure traditional value, especially in the context of social life within pure values of communities, helping each other to the wellbeing of life together.

The reassessment process of youth involvement in volunteerism should be started by identifying the factors that encourage their involvement in such activities. These stimulant factors will eventually need to be stimulated continuously to enhance youth engagement in volunteerism. This study was conducted to develop and test the validity and reliability of the items to measure the involvement of students in voluntary activities at the community level.

2. Issues & Problem

In order to achieve the status of a high-income developed country, there is a price that we have to pay, especially in terms of value drops. One of the issues most recently debated is the deterioration of volunteerism among community members, in particular involving the younger generation. This generation is seen as increasingly moving away from social voluntary activities such as collaborative activities to clean up the neighbourhood area, help community that face disaster, help in funerals, join religious activities at mosques and others, joining safety guides and so on. The issue of youth involvement in voluntary activities seems clearer when open-ended lifestyles and democratic practices are implemented. Such a lifestyle has caused the significant drop in youth involvement in volunteerism compared to the level of engagement of older generations (Zhang and Lallana, 2013), whose majority still maintains a long-lived culture.

Despite the fact that there are still youths who engage in community activities, more youths like spending time on less useful things like hanging out at the beach, participating in concerts, entertaining, vehicle racing and committing crimes. Youths are often dizzy due to lack of involvement in social issues (Warren *et al.*, 2014). It is worsening the situation as criticisms by the public and other members of the community are not heeded by the youths. Recent situations indicate that youth are less responsible in helping others (Sarimah, 2014), not engaging in social activities, and are only in the group of their own peers.

Based on the findings of the Malaysia Youth Development Research Institut (2013) study on 21, 665 youths throughout Malaysia in 2012, 19% (4, 117) youths were found to be doing leisure activities, compared to 66% (14, 299) youths spent their free time watching VCD or DVD, 63% (13, 649 people) used social sites, 54% (11, 699 people) and 50% (10, 833 people). The results of this study show that the percentage of youth engaging in voluntary work activities during their free time is still low.

Not only do the general youths have this problem, but the involvement of youths at higher educational institutions is also at a low level. Universities are the best place to raise awareness and train youth about their role in social and community development. But in terms of progress, the current youth participating in the university is very low (Sarimah, 2014). It is alarming to know that education has succeeded in producing youths who are so knowledgeable and skilled in technology, but are less interested in voluntary activities (Sarimah, 2014). Supposedly high-profile individuals are more likely to have many opportunities in voluntary engagements, but they are also easy to be affected and remain neglected (Head, 2011).

The attitude of the youth themselves which is not concerned with the social issues that occur in the community (Warren *et al.*, 2014) especially in their residential areas is also a cause for them not engaging in volunteerism. This development leads to the worsening of youth involvement in volunteerism (Delli, 2000). This phenomenon is very worrying, giving the impression that the noble values in the community are increasingly eroding and disappearing. If this situation continues, an important core that forms the well-being of a community life will collapse, as well as undermine the major axis of a nation. These issues need to be debated again, to find the causal factors, and to develop short-term and long-term solution plans.

3. Community Volunteerism

Volunteerism can be defined as the act of doing something at its own will, the sincere intention, and without compulsion to contribute positively to the environment, individuals, groups or communities without receiving financial rewards (Azizan, 2013); (Wilson, 2000) Involvement can also be referred to a form of social interaction, that is, there are parties engaged in an activity and will participate and work together to actively take part in creating, planning and carrying out mutual volunteer activities (Teuku and Abdul, 2013).

Additionally, volunteerism participation also refers to the individual's ability in obtaining resources, facilitating entry and decision-making in various areas involving the community (Toks, 2015), including economic, cultural, social, health, education, placement and poverty. The involvement of volunteerism can be either individually or collectively, organically or spontaneously (Huntington *et al.*, 1976). Collective voluntary involvement in the organization will last longer and is more effective than spontaneous, individual or temporary involvement (Teuku and Abdul, 2013). Examples of collective and organizational involvement are as practised by non-governmental organizations (NGOs) today.

Although the culture of volunteerism is a noble tradition of a society and is widely cultivated by the previous generation, it is increasingly marginalized by the current generation, especially among youth and young people (Haslinda *et al.*, 2012; Ibrahim, 2012), and university students. Generations now prefer to live on their own, and are less interested in engaging in community-based activities. As a result, many of the previous activities that were managed by community members had to be handed over to the private sector that offered the service, or handed over to the government authorities.

In order to address the problems that have ruined the value of this society, several studies have been conducted (Azizan, 2013), (Ibrahim, 2012), but the issue has not been resolved, and it is becoming even worse (Ibrahim, 2012). These studies have yet to find the most significant contributing factors to contribute effectively and comprehensively

to the participation of volunteerism among youths. Furthermore, researchers and social scholars continue to suggest that investigations, research, discussions and discourses to address this issue are made without tears, until our social system finds a powerful recipe to address these problems.

4. Measures

This study used a cross-sectional survey design using quantitative methods. The respondents of the study consisted of 150 students from Institutes of Higher Education (IPTA) in the East Coast of Peninsular Malaysia selected through purposive sampling. The data were collected using a questionnaire with the respondents required to respond to their involvement in voluntary activities in the community, with indicators starting from 'never' to the most frequent 'very often'. A total of 10 items were used to measure their involvement in activities such as cleaning up neighbourhood area, helping community that face disaster, helping in funerals, joining religious activities at mosques and others, joining safety guides and so on. Details of the items in the questionnaire are shown in [Table 1](#) in the section of research result. Pilot studies that were conducted on 30 samples in Terengganu show that this instrument has Alpha reliability coefficient of 0.8, while all items correlate at moderate rate ($r = 0.4 - 0.6$).

The data was analysed using the structural equation modelling (SEM) approach by AMOS 20 software focusing on standard loading, convergent validity, composite reliability, discriminant validity and fit indexes. The items of the measurement will be accepted when the regression weight for every standard loading is 0.708 and above (consider to be accepted for 0.4 and above if AVE achieved), average variance extracted (AVE) for convergent validity is 0.5 and above, composite reliability (CR) is 0.708 and above, square root AVE for discriminant validity greater than value of correlation between item ([Hair et al., 2012](#)). The model is also assumed to be fit when at least one fit index from each category namely basic, relative and parsimony was achieved where CMIN ratio < 5 , CFI and NFI > 0.9 , PCFI and PNFI > 0.5 , and RMSEA < 0.1 ([Meyers et al., 2013](#)).

For preliminary analysis, items and variable of volunteerism are considered low if the score mean is below 2.00, moderate level for score mean is between 2.01 and 3.00, and high level for mean is above 3.01.

5. Result

Generally, the findings show that the level of involvement in volunteerism among students is moderate. Of the 10 measured indicators, involvement in funeral management activities, involvement in neighbourhood security controls and involvement in non-governmental organizations (NGOs) were at low levels, while the rest was at moderate levels. Out of the 10 indicators measured, no indicator is shown to be at the high level. The details of the result are shown in [Table 1](#) below, including the finding of normality testing.

Table-1. Preliminary Result

Item	Participation	Mean	Level	Sd	Skew.	Kurt
V1	I was helping out with feast preparation.	2.599	Moderate	0.074	0.045	-0.863
V2	I was helping out with funeral when there is a death.	1.757	Low	0.057	0.489	-0.426
V3	I was helping those affected by disasters such as floods, storms, fires and so on.	2.217	Moderate	0.065	0.353	-0.254
V4	I was involved in security control activities in the neighbourhood.	1.691	Low	0.064	0.928	0.184
V5	I was participating in community activities in mosques and other synagogues.	2.217	Moderate	0.064	0.411	-0.104
V6	I was joining collaborative activity to clean the housing area, care for public facilities and so on.	2.322	Moderate	0.067	0.260	-0.424
V7	I also get involved when a neighbour is affected by illness or distress.	2.382	Moderate	0.064	0.028	-0.454
V8	I am joining a non-governmental organization (NGO) which conducts volunteer work.	1.947	Low	0.072	0.669	-0.311
V9	I was participating in social activities organized in the community.	2.336	Moderate	0.067	0.287	-0.412
V10	I was inviting other friends to participate in volunteer activities in the community.	2.322	Moderate	0.069	0.371	-0.412
Volunteerism		2.179	Moderate	0.0663	0.3841	-0.347

The findings also show that all items are inter-correlated at a moderate level as shown in [Table 2](#) below. This finding indicates that the items are interdependent, while at the same time discriminating against each other to avoid multicollinearity phenomenon. This is in line with the need that items within the same construct need to be interconnected with each other, but at the same time not very similar.

Table-2. Inter-item Correlation

Variables	Vol	V10	V9	V8	V7	V6	V5	V4	V3	V2	V1
Vol	1.00										
V10	.664	1.00									
V9	.747	.496	1.00								
V8	.631	.419	.471	1.00							
V7	.720	.478	.538	.454	1.00						
V6	.799	.530	.597	.504	.575	1.00					
V5	.752	.499	.562	.474	.541	.600	1.00				
V4	.628	.417	.469	.396	.452	.501	.472	1.00			
V3	.716	.475	.535	.451	.515	.572	.538	.450	1.00		
V2	.595	.395	.444	.375	.428	.475	.447	.373	.426	1.00	
V1	.576	.382	.430	.363	.414	.460	.433	.361	.412	.342	1.00

The findings in [Table 3](#) below show the average variance extracted (AVE) to test the convergent validity which is 0.500, the AVE's square root for testing the discriminant validity is 0.707, and the composite reliability is 0.898, while all the standard loading values exceed 0.4. The AVE square root value is also greater than the inter-correlation between the items that are shown in [Table 2](#) above. These findings confirm that these proposed items are valid and reliable to measure the involvement of students in volunteerism.

Table-3. Standard Loading, Convergent Validity, Discriminant Validity & Composite Reliability

Variable	Item	SL	AVE	\sqrt{AVE}	C.R
Volunteerism	V1	.576	0.500	0.707	0.898
	V2	.595			
	V4	.628			
	V5	.752			
	V3	.716			
	V6	.799			
	V7	.720			
	V8	.631			
	V9	.747			
	V10	.664			

Lastly, the test to see the fitness of the model also shows all the index categories i.e. basic, relative and parsimony achieved the needed score, which confirms that the collected data was fit to the proposed measurement model. The findings are shown in [Table 4](#) below.

Table-4. Model Fitness

Fitness indexes	Required	Result
χ^2	Small better	124.124
χ^2/df	< 5	3.546
CFI	> 0.90	0.921
RMSEA	< 0.10	0.097
PCFI	>0 .50	0.680
PNFI	>0 .50	0.650

The final model that summarizes the arrangement of items, standard loading scores and result of fitness testing is shown in [Figure 1](#) below. This figure confirms that all 10 indicators that were suggested to measure student involvement in volunteerism are valid and reliable.

Figure-1. Final Model

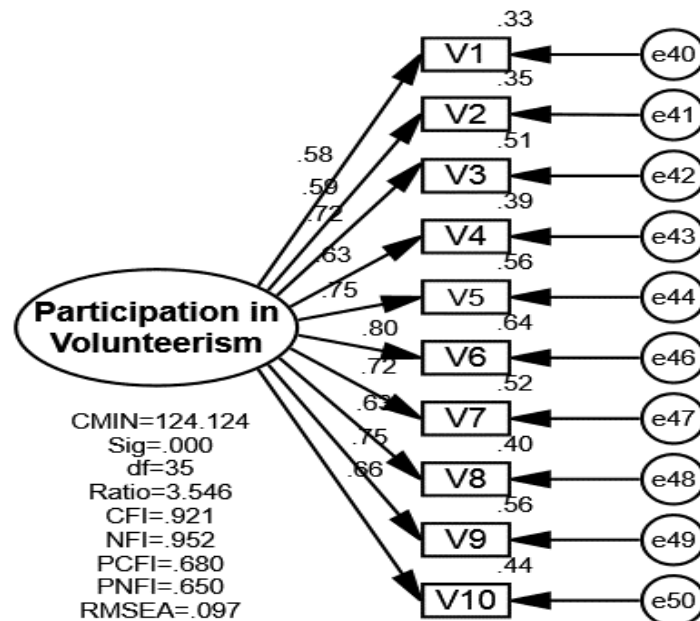

6. Conclusion

This study has successfully identified a scale that can be used to measure student engagement in volunteerism at the community level. The study also developed a measurement model to measure the involvement of students and youth in volunteerism.

This finding can be used by future researchers to study the behaviour of voluntary involvement in more detail, as well as recommend the best measures to encourage the involvement of youth and university students in volunteerism.

This finding can also be used by the parties to recognize recognition of volunteering involved in volunteerism. Universities, governments, NGOs, private companies and so on can use this scale to identify youth who are immersed in volunteerism, thus being rewarded for such engagement.

For employer recruitment, employers are also encouraged to prioritize youth who are involved in volunteerism. This measurement scale can be used by employers to select the best prospective employees, especially those who are involved with the community.

References

- Azizan, B. (2013). *Menghayati Kerja Sukarela*. Petaling Jaya, Qarya Sdn Bhd.
- Delli, C. (2000). Gen.com, Youth, civic engagement, and the new information environment. *Political Communication*, 17(4): 341-49.
- Ezhar, T. and Madiha, H. (2015). Predicting interethnic bridging social capital in youth ethnic-diversity engagement, The role of interethnic interaction and intercultural sensitivity. *International Journal of Adolescence and Youth Jun*, 21(1): 1-4.
- Hair, F., Sarstedt, M., Ringle, M. and Mena, A. (2012). An assessment of the use of partial least squares structural equation modeling in marketing research. *Journal of the Academy of Marketing Science*, 40(3): 413-33.
- Haslinda, A., Dzuhailmi, D., Azimi, H., Ismi, A. I., Ezhar, T., Abdul-lateef, A. and Gill, N. A. (2012). Majlis Belia Malaysia, Quo vadis transformasi era semasa. *Malaysia Journal of Society and Space*, 7(7): 13-19.
- Head, B. W. (2011). Why not ask them? Mapping and promoting youth participation. *Children and Youth Services Review*, 33(4): 541-47.
- Ho, E., Clarke, A. and Dougherty, I. (2015). Youth-led social change, Topics, engagement types, organizational types, strategies, and impacts *Futures*, 67(2015): 52-62.
- Huntington, Samuel, P. and Joan, N. M. (1976). *No Easy Choice*. Harvard University Press: Cambridge.
- Ibrahim (2012). Faktor penentu tahap kesukarelawanan dalam kalangan belia berpersatuan Di Malaysia, Satu Analisis Perbandingan Kumpulan Etnik. Laporan penyelidikan UMT, tidak diterbitkan.
- Malaysia Youth Development Research Institut (2013). Masa lapang belia mengikut aktiviti. Available: http://www.ipbpm.gov.my/index.php?option=com_content&view=article&id=795:masa-lapang-belia-mengikut-aktiviti&catid=146&Itemid=453&lang=ms
- Meyers, L. S., Gamst, G. and Guarino, A. J. (2013). *Applied multivariate research, Design and interpretation*. 2nd edn: Sage Publication: London.
- Sarimah, I., 2014. "Youth volunteerism in Chow Kit, Malaysian, Factors of involvement." International Conference on Global Trends in Academic Research, Kuala Lumpur. pp. 2-3.

- Teuku, A. and Abdul, R. E. (2013). Komuniti dan pengurusan persekitaran, Beberapa pengalaman Malaysia, Bangladesh, Zambia dan Vietnam. *Kertas Kajian Malaysia*, 31(2): 65-86.
- Toks, O. (2015). Participation, citizenship and internet use among South African youth. *Telematics and Informatic*, 32(2015): 11-22.
- UNESCO (2012). Social and human sciences, Acting with and for youth. Available: <http://www.unesco.org/newen/social-and-human-science/themes/youth>
- Warren, A. M., Sulaiman, A. and Jaafar, N. I. (2014). Facebook, The Enabler of online civic engagement for activist. *Computer in Human Behavior*, 32(2014): 284-89.
- Weinstock, H., Berman, S. and Cates, W. (2004). Sexually transmitted diseases among American youth, Incidence and prevalence estimates, 2000. *Perspectives on Sexual and Reproductive Health*, 36(1): 6-10.
- Wilson, J. (2000). Volunteering. *Annual Review of Sociology*, 26(2000): 215-40.
- Zhang, W. and Lallana, E. C. (2013). Youth, ICTs, and civic engagement in Asia. *International Communication Gazette*, 75(3): 249-52.