

The Measurement Model of Virtual Instructional Leadership: Confirmatory Factor Analysis Approach

Mohd Yusri Ibrahim*

Centre for Fundamental and Liberal Education, Universiti Malaysia Terengganu, Malaysia

Mat Rahimi Yusof

School of Education and Modern Language, Universiti Utara Malaysia, Malaysia

Masduki Mohammad Morni

Centre for Fundamental and Liberal Education, Universiti Malaysia Terengganu, Malaysia

Mohammad Mahdi Abas

Centre for Fundamental and Liberal Education Universiti Malaysia Terengganu, Malaysia

Kasawani Ibrahim

Centre for Fundamental and Liberal Education, Universiti Malaysia Terengganu, Malaysia

Azhar Mohd Sinin

Centre for Fundamental and Liberal Education Universiti Malaysia Terengganu, Malaysia

Mohammad Zaidi Mahadi

Centre for Fundamental and Liberal Education Universiti Malaysia Terengganu, Malaysia

Abstract

Virtual instructional leadership model (VILM) consists of seven constructs namely communicating the school's goals, supervising and evaluating instruction, monitoring students' progress, providing incentives for teachers, providing incentives for students, integrating mobile technology and getting involved in community support. The objectives of the study were to develop a computational of measurement model, evaluate and prove the suggested construct and indicators for VILM among principals. Data from 155 respondents collected through questionnaire were analyzed using AMOS version 22. The suggested constructs and indicators were considered accepted as measurement elements by observing a regression weight for loading factor, average variance extracted (AVE) for convergent validity, composite reliability (CR) for item reliability, the square root of AVE (\sqrt{AVE}) for discriminant validity, and at least three fit indexes for model fitness. The findings showed that all constructs were significant (FL= 0.80-0.91; AVE= 0.646-0.944; CR= 0.834-0.960). Finally, this study was successfully developed a measurement model of virtual instructional leadership model. Therefore, these models can be used for school leaders, accessed future research or any type of program in order to improve the instructional leadership.

Keywords: Virtual instructional leadership; Mobile technology; Virtual communication; Social media and communication apps.



CC BY: [Creative Commons Attribution License 4.0](https://creativecommons.org/licenses/by/4.0/)

1. Introduction

The Malaysian Education Blueprint (2013-2025) illustrates the government's efforts to produce knowledgeable young people, think critically and creatively, have strong leadership skills and effectively communicate globally (Kementerian Pendidikan Malaysia, 2013). One of the key elements to form quality students and competent teachers is through school leadership.

This intention is clearly emphasized in chapter 5 of the PPPM (2013-2025). Leadership is often an important topic in the organization (Hallinger, 2009). The results of effective school research in more than three decades formulated an effective school leader as a major factor in the success of a school (Hornig and Loeb, 2010; Hoy and Miskel, 2013); Ibrahim and Aziz (2014) ; (Zaidatol and Soaib, 2011). One of the elements that need to be emphasized in the leadership of school leaders is instructional leadership.

2. Issues in Instructional leadership

The debate about the definition of instructional leadership which is still going on since 1970's until now is still endless (Bas, 2012; Glasman, 1984; Hallinger and Murphy, 1985a;1985b). The differences in definition have caused different models were developed such as Hallinger and Murphy's model (1985), Murphy's Model (1990) and Weber's Model (1996). However, the Hallinger and Murphy's model (1985) was accepted among researchers (Hallinger, 2011).

Based on the literature study, the definition of instructional leadership can be summarized as principals' behaviors to improve teaching and learning, improving teacher teaching competencies and improving students' academic achievement (Glasman, 1984; Hallinger and Murphy, 1985a;1985b; Ibrahim, 2012; James and Balasandran, 2013; Lipham *et al.*, 1985). However, technological developments also influence the definition of leadership as principals' behavior that integrates the use of ICT & mobile technology in their leadership style and practice (Ibrahim and Amin, 2013; Larry, 2002; Lee, 2010).

In the context of practice in Malaysia, instructional leadership began to attract attention to school leaders after the study found that instructional leadership had significant relationships to producing an effective school (Sazali *et al.*, 2007). Until now, competent instructional leadership and high achievers are needed in contributing to the academic and school excellence by placing high-performance instructional leaders in all schools (Ministry of Education, 2013).

To realize that, more than 1,371 teachers chose to take the National Professional Qualification for Educational Leaders (NPQEL) course in 2015. Hence, principals are often urged to practice instructional leadership in order to improve education excellence (Hallinger, 2011). In fact, principals face constraints on practicing all the functions of instructional leadership (Ministry of Education, 2013) due to the fact that they are busy with administrative tasks such as attending meetings, workshops and conferences Bity *et al.* (2010); Jamelaa and Jainabee (2011); Ibrahim and Amin (2013); Ibrahim (2012); Taat and Minhat (2013). He principals do not have much time to focus on the curriculum and teaching (Jamelaa and Jainabee, 2011); (Jamilah and Yusof, 2011).

Principals lack the time to discuss and guide teachers especially in teaching. Group communication becomes less effective when leaders are less in touch with their employees (Arsaythamby and Komuji, 2013). The business that principals have to handle also limits the active and effective communication of principals and teachers. Ibrahim and Amin (2013). To address this problem, researchers suggest that principals integrate mobile technology into instructional leadership.

However, despite numerous studies on virtual leadership and instructional leadership, but relatively fewer studies related to virtual instructional leadership. Because of that, the objectives of this study aims to develop a computational of measurement model to evaluate and prove the suggested construct and indicators for virtual instructional leadership among principals.

Referring to the issues and previous studies, the hypothesis model as in the following was proposed for this study.

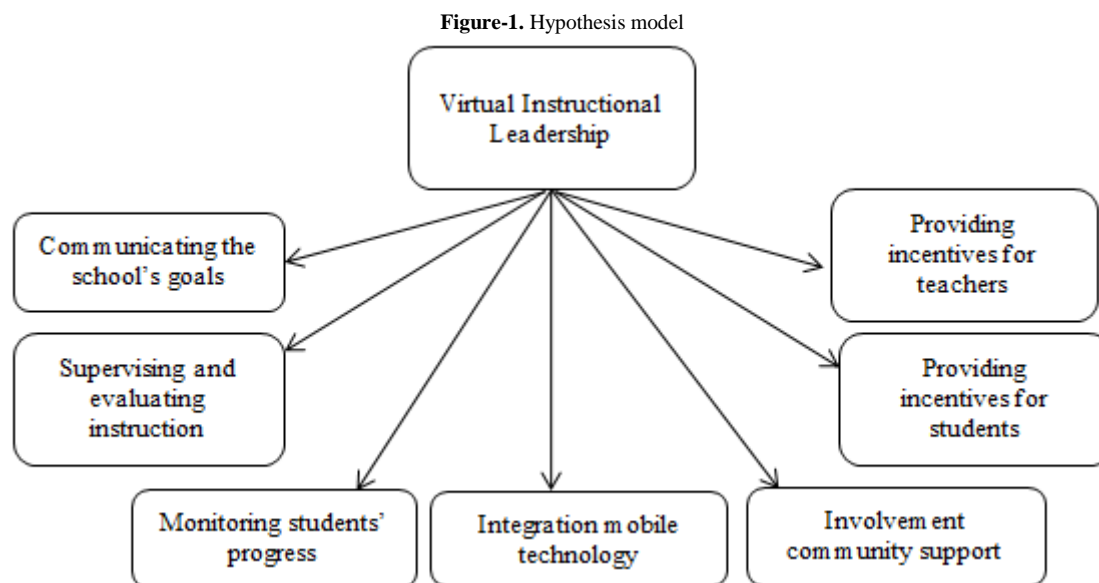

Based on the hypothesis model, virtual instructional leadership will be measured by seven constructs namely communicating the school's goals (CSI), supervising and evaluating instruction (SEI), monitoring students' progress (MSP), integration mobile technology (IMT), providing incentives for students (PIS), providing incentives for teachers (PIT), and involvement community support (ICS).

3. Measures

This quantitative study applied a cross-sectional study design. The data were collected using questionnaire among 155 teachers of secondary school (SMK) and secondary religious school (SABK) teachers in the district of Besut and Setiu, Terengganu who are determined using stratified random sampling technique and the formula for the determination of sample size of Krejcie and Morgan (1970). There were 62 (40%) male, 93 (60%) female, 5 (3.2%) teachers from school in urban and 150 (96.8%) teachers from school in rural, 128 (82.6%) from SMK and 27 (17.4%) from SABK.

The data were analyzed by using Structural Equation Model (SEM) with AMOS 22 program focusing on loading factor, convergent validity, composite reliability, discriminant validity and fit indexes. The item, constructs,

and variable of the model will be accepted when regression weight for every standard loading are 0.708 and above, composite reliability (CR) are 0.708 and above, Average Variance Extracted (AVE) are 0.5 and above, and square root AVE (\sqrt{AVE}) for discriminant validity greater than value of correlation between item and construct. The model also assume as fit when at least one fit index from each category namely basic, relative and parsimony was achieved where CMIN ratio <5, CFI and NFI > 0.9, PCFI and PNFI > 0.5, and RMSEA <0.1 (Chua, 2009; Hair *et al.*, 2012; Ibrahim, 2012; Meyers *et al.*, 2013; Zainuddin, 2014).

4. Results and Discussion

The preliminary results showed all the constructs were acceptable values for skewness and kurtosis which means all variables were in normal distributed and the parametric testing can be done. The preliminary result was shown in table 1.

Table-1. The Preliminary Result

	Min	sp	skew	kurtosis
1. ICS	3.192	.073	-.636	.242
2. PIS	3.508	.082	-.544	.010
3. PIT	3.427	.078	-.515	.086
4.IMT	3.519	.068	-.421	.022
5.CSG	3.210	.073	-.432	-.078
6.SEI	3.149	.081	-.466	-.505
7.MSP	3.103	.074	-.499	-.401

The result also showed that all construct were strength correlate with each other as shown in the table. 2

Table-2. Inter- Construct Correlation (AVE shows in diagonal)

	1	2	3	4	5	6	7
1. ICS	0.803						
2. PIS	.718	0.700					
3. PIT	.765	.748	0.767				
4.IMT	.732	.716	.763	0.721			
5.CSG	.660	.645	.688	.658	0.924		
6.SEI	.686	.671	.715	.684	.617	0.944	
7.MSP	.720	.704	.750	.718	.647	.673	0.730

The finding showed the factor loading for all indicators were achieved with factor loading values are above 0.5. This finding showed that all suggested indicators (C1- C38) were accepted and measured the constructs. Meanwhile, Table 3 shows that the results of factor loading for each construct in virtual instructional leadership model.

Table-3. Factor Loading

Constructs	Item Indicators	Factor loading
Communicating The School's Goals	C1- C6	0.724 - 0.854
Supervising and Evaluating Instruction	C7 - C12	0.801 - 0.946
Monitoring Students' Progress	C13 - C18	0.668 - 0.868
Integration Mobile Technology	C19 - C24	0.640 - 0.822
Providing Incentives for Teachers	C25 - C29	0.876 - 0.906
Providing Incentives for Students	C30 - C33	0.904 - 0.955
Involvement Community Support.	C34 - C38	0.656 - 0.869

Next, referring to table 4, it is shown that all measurement of convergent validity (AVE), composite reliability (CR) and discriminant validity (\sqrt{AVE}) was achieved. This result indicates that all the indicators and constructs were suggested for the virtual instructional leadership valid and reliable. Table 4 shows the convergent validity, composite reliability and discriminant validity for the constructs of virtual instructional leadership.

Table-4. Convergent Validity, Composite Reliability and Discriminant Validity

Constructs	CR > 0.708	AVE > 0.5	√AVE
Communicating The School's Goals	0.924	0.803	0.896
Supervising and Evaluating Instruction	0.957	0.944	0.972
Monitoring Students' Progress	0.917	0.730	0.854
Integration Mobile Technology	0.944	0.767	0.849
Providing Incentives for Teachers	0.944	0.876	0.876
Providing Incentives for Students	0.965	0.700	0.837
Involvement Community Support	0.852	0.646	0.804

Figure 1. shows the final model of virtual instructional leadership. All suggested indicators were accepted and reflected constructs or elements to the virtual instructional leadership with 0.80 to 0.91 of factor loading. The fit indexes of the virtual instructional leadership model as shown in the model was also fit.

Figure-1. Final model of virtual instructional leadership

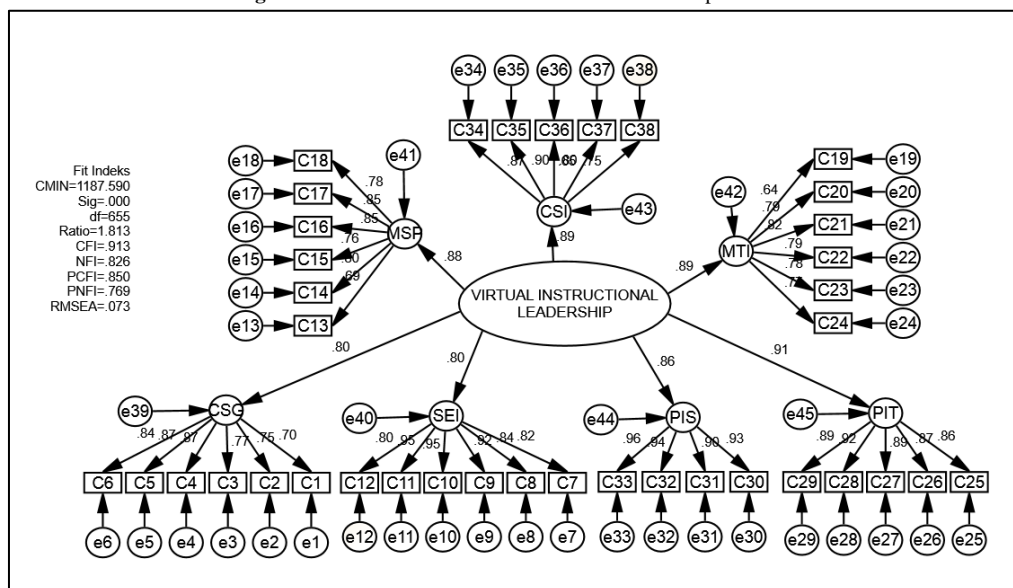

Finally, this study successfully developed the measurement model of virtual instructional leadership which consists of 38 indicators and seven functions. The functions are communicating the school's goals, supervising and evaluating instruction, monitoring students' progress, providing incentives for teachers, providing incentives for students, integrating mobile technology and getting involved in community

5. Conclusion

Generally, this study successfully developed the measurement model of virtual instructional leadership among school leaders. The study also successfully developed and validated 38 items indicators for the seven constructs in virtual instructional leadership practice. Two new functions of virtual instructional leadership that integrates mobile technology and involve community support can be verified.

In order to improve the skill of virtual instructional leadership, school leaders are encouraged to practice this model in their instructional leadership. Besides that, school leaders are encouraged to fully apply the power of mobile technology, social networking, and social media in school.

Instructional leadership functions can be applied at anytime and anywhere with mobile technology and the new medium of communication. The busy of administration works is no longer a major barrier in practicing holistic instructional leadership functions. Principals should take advantage of the advancement of mobile technology by increasing their knowledge and skills. Principals should dare to use or integrate technology in their instructional leadership.

In addition, the acceptance of functions which involve community support indicates that community involvement is very important in improving school effectiveness. In this case, a new medium of communication like WhatsApp, Telegram, and Facebook can help principals enhance relationships with the community. All information and information can be communicated to the community.

Therefore, it is proposed that principals apply this virtual instructional leadership model in their instructional leadership. In the future, it is proposed that future researchers be able to carry out further studies using the questionnaires that have been confirmed for the improvement of this model.

References

- Arsaythamby, V. and Komuji, M. M. A. (2013). Kesan penyeliaan klinikal terhadap prestasi pengajaran guru sekolah menengah. *Asia Pacific Journal of Educators and Education*, 28(1): 81-102.
- Bas, G. (2012). Correlation between school principals' instructional leadership behaviours and teachers' organisational trust perceptions. *Middle Eastern and African Journal of Educational Research*, 1(16): 7-18.
- Bity, S. A., Ahmad, B. M. Y., Ramlee, M. and Mohammed, S. I. (2010). Analisis kompetensi pengetua berdasarkan kualiti peribadi, Pengetahuan, Kemahiran dan qamalan pengurusan sekolah menengah Malaysia. *Jurnal Pendidikan Malaysia*, 35(2): 31-41.
- Chua, Y. P. (2009). *Asas statistik penyelidikan, Analisis data skala ordinal dan skala nominal*. Mc Graw Hill, M: Shah Alam.
- Glasman, N. S. (1984). Student achievement and the school principal. *Educational Evaluation and Policy Analysis*, 6(3): 283-96.
- Hair, J. F., Sarstedt, M., Pieper, T. M. and M, C. R. (2012). The use of partial least squares structural equation modeling in strategic management research, A review of past practices and recommendations for future applications. *Long Range Planning*, 45(5-6): 320-40.
- Hallinger, P. (2009). *Leadership for 21st century schools, From instructional leadership to leadership for learning*. The Hong Kong Institute of Education: Hong Kong.
- Hallinger, P. (2011). Leadership for learning, Lessons from 40 years of emperial research. *Journal of Educational Admistration*, 49(2): 125-42.
- Hallinger, P. and Murphy, J. (1985a). Assessing the instructional management behavior of principals. *Educational Leadership*, 86(2): 217-47.
- Hallinger, P. and Murphy, J. (1985b). Assessing the instructional management behavior of principals. *The Elementary School Journal*, 86(2): 217-47.
- Hornig, E. and Loeb, S. (2010). New thinking about instructional. *Kappan Magazine*, 1(6): 66-69.
- Hoy, W. K. and Miskel, C. G. (2013). *Educational administration*. 9th edn: Mc Graw Hill Higher Education: New York.
- Ibrahim, M. Y. (2012). *Model kepimpinan pengajaran pengetua efikasi dan kompetensi pengajaran*. Universiti Malaysia Terengganu.
- Ibrahim, M. Y. and Amin, A. (2013). *Model e-kepimpinan, komunikasi kumpulan dan kepuasan kerja dalam kalangan pemimpinsekolah*. In seminar nasional pengurusan dan kepimpinan pendidikan ke- 20. Institut Aminuddin Baki: Genting Highlands.
- Ibrahim, M. Y. and Aziz, A. (2014). Model kepimpinan pengajaran pengetua dan kompetensi pengajaran guru. *Jurnal Kurikulum Pasifik, Pengajaran Asia Pasifik*, 22(1): 11-25.
- Jamelaa, B. A. and Jainabee, M. K. (2011). Amalan kepimpinan instruksional dalam kalangan pengetua sekolah menengah di negeri pahang, satu kajian kualitatif. *Journal of Edupres*, 1: 323-35. Available: <http://eprints.utm.my/17080/1/JOE-1-2011-039.pdf>
- James, A. J. E. and Balasandran, R. (2013). *Kepimpinan instruksional satu panduan praktikal, Kedua*. PTS Akademia: Batu Caves.
- Jamilah, A. and Yusof, B. (2011). Amalan kepimpinan sekolah berprestasi tinggi (sbt) di. *Journal of Edupres*, 1(September): 323-35.
- Kementerian Pendidikan Malaysia (2013). *Pelan pembangunan pendidikan Malaysia 2013 - 2025, pendidikan prasekolah hingga lepas menengah*. Kementerian Pendidikan Malaysia: Putrajaya.
- Larry, L. (2002). Developing instructional leaders. *ERIC ED*, 46(160): 1-8.
- Lee, M. (2010). *E-leadership for project managers, A study of situational leadership and virtual project success*. Capella University.
- Lipham, J., Rankin, R. and Hoeh, J. (1985). *The principalship, Concepts, competencies and cases*. Longman: New York.
- Meyers, L. S., Gamst, G. and Guarino, A. J. (2013). *Applied multivariate research, Design and interpretation*. 2nd edn: Sage Publication: London.
- Ministry of Education (2013). *Malaysia educational blue print 2013-2025*. MOE: Putrajaya.
- Sazali, Y., Rusmini, K. A., Abang, H. A. E. and Zamri, A. B. (2007). Perkaitan antara kepimpinan instruksional terhadap sekolah berkesan. *Jurnal Pengurusan IAB*, 1(1): 107-19.
- Taat, M. S. and Minhat, M. (2013). *Pengaruh dimensi kepimpinan instruksional pengetua terhadap komitmen kerja guru di sabah*. In seminar kebangsaan kali ke iv majlis dekan ipt 2013. Universiti Islam Antarabangsa: Gombak. 449-57.
- Zaidatol, A. L. P. and Soaib, A. (2011). *Transformasi Kepimpinan pendidikan cabaran dan hala tuju*. Penerbit Universiti Putra Malaysia: Serdang.
- Zainuddin, A. (2014). *A handbook on SEM for academicians and practioners*. MPWS Rich Resources: Bandar Baru Bangi.