



Geometrical Analysis and Design of Tension-Actuated Ackermann Steering System for Quad-Wheeled Robots

Mbadiwe Benyeogor (Corresponding Author)

Faculty of Physics and Electrical Engineering, University of Bremen, Bremen, Germany

Email: mbadiwe@uni-bremen.de

Sushant Kumar

Faculty of Physics and Electrical Engineering, University of Bremen, Bremen, Germany

Article History

Received: December 27, 2019

Revised: January 20, 2020

Accepted: January 28, 2020

Published: January 30, 2020

Copyright © 2020 ARPG & Author

This work is licensed under the Creative Commons Attribution International

 **CC BY:** Creative Commons Attribution License 4.0

Abstract

The tension-actuated steering system is a vehicular steering design that comprises a motorized gear system, pulleys, inelastic string, main steering bar, and a strain gauge. This development is aimed to produce a steering design that could enhance the efficiency of steering systems in quad-wheeled (i.e. four-wheeled) robots. In this work, the steering system of conventional passenger vehicles and existing quad-wheeled robots are reviewed and their technical deficiencies are improved based on cost, power and production factors. Thus, the tension-actuated steering system is proposed as a solution for mechanizing steering functions in quad-wheeled robots. It is expected that this work will stimulate interest and enthusiasm.

Keywords: Ackermann steering; Strain gauge; Slide collar; Quad-wheeled robot.

1. Introduction

The tension-actuated steering system is a pulley-motor-gear system that can be used for the implementation of the Ackermann steering geometry – a mechanical arrangement for steering the front wheels of a vehicle, four-wheeled mobile robots or toy cars [1]. Conventional steering system, which can be of manual, electrical, pneumatic or hydraulic design; incorporate some form of rack and pinion gear arrangement that convert the initial torsion (twisting force or torque) from the steering wheel or motorized gear assembly (as in unmanned vehicles and wheeled robots) into linear motion, so that the tie rod adjustment sleeves transform the default rectangular front wheel alignment to trapezoidal form and causing the wheels to twist [1].

It has been observed that most wheeled-robot engineers, transport-toy designers, and hobbyists find it technically difficult and costly to implement the Ackermann steering geometry on their project or prototype. Therefore, they either have to construct or purchase and install a rack/pinion gear steering system for their project; some even go on to unfasten steering ratchet from a disused small car as a scrap and reconstruct it to fit into their mechanical design, which impacts negatively on the entire project, as the project loses its originality. The main cause for these is the high-cost of machine tools, which are being used for forming workpiece into rack and pinion gear parts; as these can only be afforded by large automobile manufacturers or robotic companies [2]; but are out of the reach of the hobbyist and the laboratory-based roboticist. Thus, the goal of this work is to provide “the tension-pull steering system” – an engineering solution to the problems which model car hobbyists and roboticists face in trying to implement the Ackermann steering system on their prototypes. The tension-actuated steering system is an electromechanical construct that can be used to effectively implement the Ackermann steering geometry at minimal cost on miniature motor vehicles like wheeled robots, radio-controlled rovers, toy cars, and many others.

2. Literature Review

In conventional quad-wheeled vehicles, the steering as a functional system controls the front wheel (sometimes the rear wheel) direction [3], maintains the correct magnitude of effort needed to turn the wheel, absorb most of the shock going to the steering wheel as the tire hits pot-holes and bump in the road, and enhances suspension action [4]. According to Jin Yao and Jorge Angeles in Jin and Jorge [5], when cars are turning, the wheels (i.e. tires) don't point the same direction (i.e. wheels turn at different angles). The inner wheel turns at a smaller radius (i.e. at a steeper angle) than the outer wheel (Fig. 1.0). Any steering systems that function in this manner are designed in adherence to the Ackermann steering geometry; hence it is said to obey the Ackermann condition [1].

Many active steering systems still use the rack and pinion gear to implement the Ackermann steering geometry; a typical example is the hydraulic power steering commonly found in large military trucks, trailers, and modern cars. Power steering normally uses the engine-driven pump and hydraulic system to assist steering action, even though it is human actuated or motorized [6]. Based on this, it is obvious that the rack and pinion gears alongside other

facilitating rigid parts have to be fabricated from a metallic workpiece using sophisticated machine tools such as the lathe, which are only available at heavy industries, auto-companies, and the universities (e.g. central lathe in production engineering workshops). The methods of machining complicated parts of these kinds as elucidated by Helmi and El-Hofy [2] would usually pose to be very difficult and expensive for the hobbyist and the roboticist; as a result, some of them adopt primitive designs to improvise for technical or fiscal inadequacies. The following sections review and mirror-out the deficiencies inherent in the steering mechanisms of contemporary quad-wheeled steering systems; a specific problem this work is set to solve.

Fig-1. Ackermann steering geometry

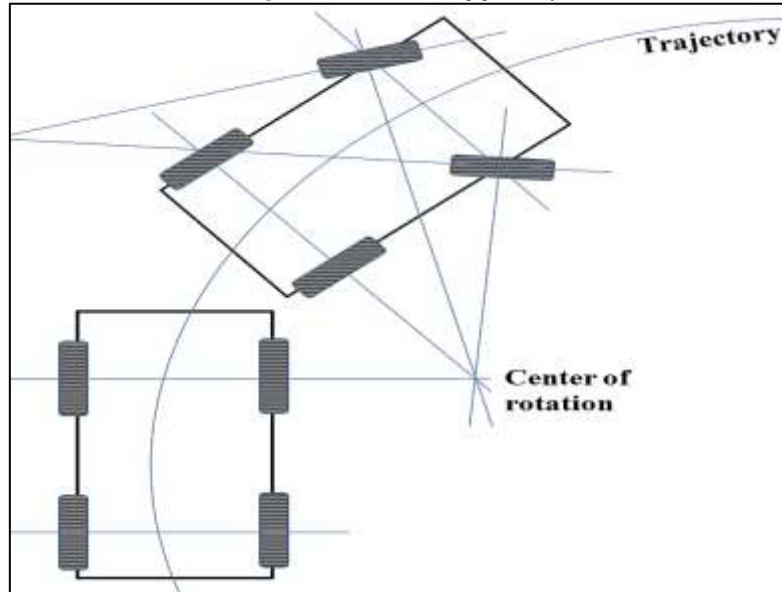

3. Methodology

The methodology adhered for the completion of this research work is initialized by the creation of the mental construct of what the tension-pull steering system would look like, outlining of this mental picture in computer-simulated diagram using a CAD-tool, conceptualization of the device using physical laws and preparation of an analytic design, and modeling of the prototype tension-actuated steering device. The remaining part of this technical report is concerned about an engineering design that could replace the rack-pinion gear system with the tension-string-gear system, to enhance the steering action of four-wheeled robots. The force output axle of the gear cluster is fitted to a hoist, which is a special small pulley with two grooves. A strain-gauge is connected along the pulling string to enable measurement and analysis of the tension in the string.

3.1. Steering Mechanism and Geometry

The tensional steering system is made-up of a motor incorporated into a force-multiplying gear system. One end of a flexible, inelastic and strong string is coiled and fixed to one of the groove of this string, and passed through a rigid metallic tube that leads it through the groove of another larger pulley out of which it is fixed to a collar sliding freely along a rail attached to and parallel to the width of the robot chassis (Fig. 2.0).

Fig-2. Bottom-view of the tensional steering mechanism

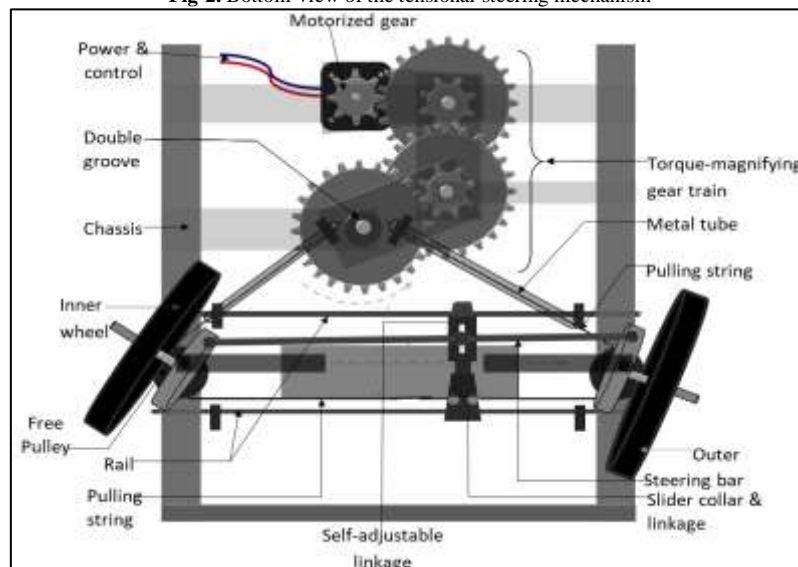

At the other end of the slide-collar is attached another string coming from the second layer of hoist groove through the usual tubing describe earlier. If the motor is powered, the gear system rotates the hoist in one direction causing one groove to wind-up its string and the other groove to unwind-out its string. If the polarity of the current used for powering the motor is changed, the reverse is observed, thereby making it possible for the sideways movement of the slide-collar along the rail. A rigid self-adjustable linkage between the slide collar and the steering bar (as shown in Fig. 3.0), transfer this resultant rectilinear motion from the slide-collar to the steering bar that pushes the wheels to twist at a spot.

For the design of the maneuvering mechanisms in many four-wheeled robots, the Ackerman steering model is usually adopted, since it is suitable for low-speed movement [1]. Hence it is also adopted for the design and modeling of the tension-actuated steering system. Consider a front-wheel-steering system that is turning to the left, as shown in Fig.4.0.

Fig-3. Frontal view of the tension-pull steering mechanism

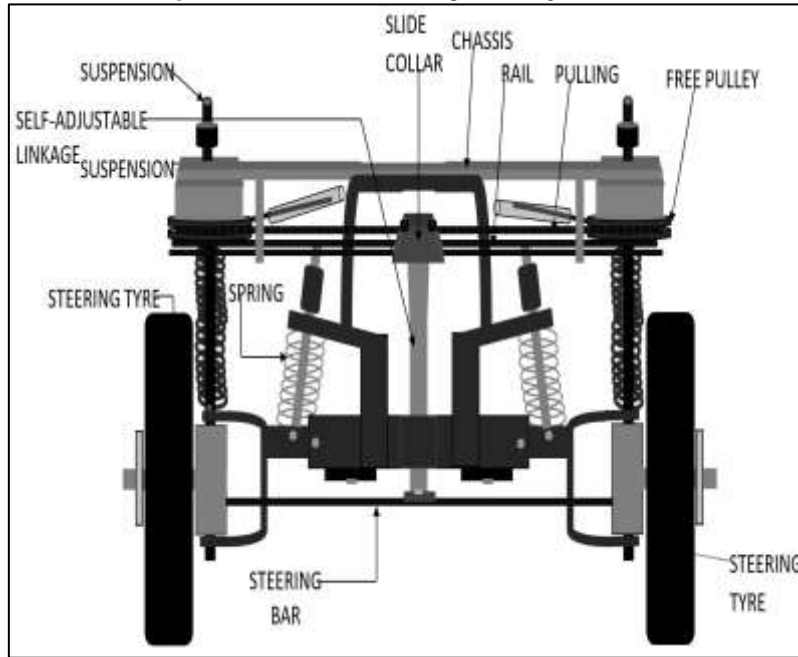

When the locomotive is moving very slowly, there is a kinematic condition between the inner and outer wheels that allows them to turn slip-free. The condition is called the Ackerman condition (or geometry).

Fig-4. Inner and outer wheels steering angles of a vehicle

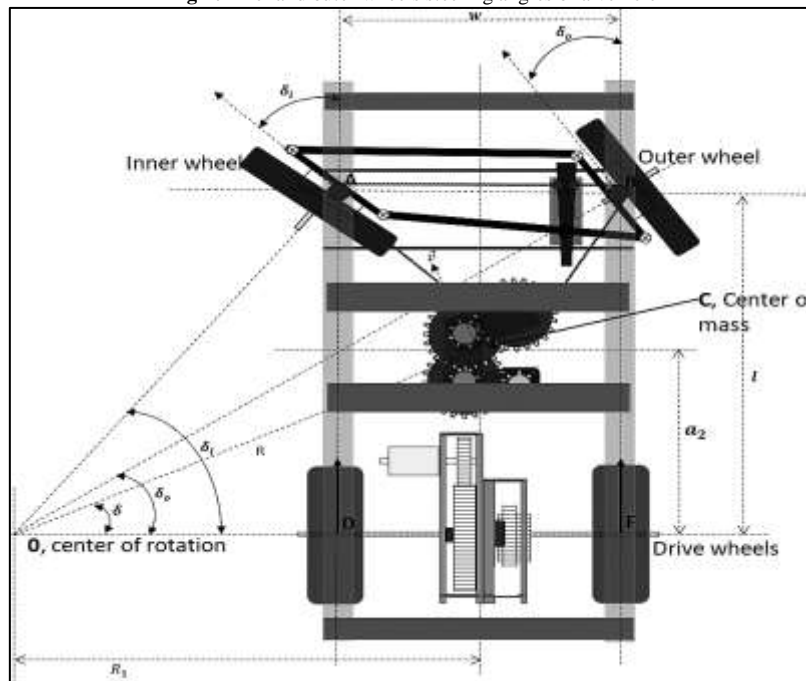

In Fig. 4.0, the vehicle front wheels are shown to be turning left. So, the center of rotation, O is on the left, and the inner wheel is the left wheel that is closer to this center of rotation. The inner and outer steering angles δ_i and δ_o may be evaluated from the triangle ΔOAD and ΔOBF as follows:

$$\tan \delta_i = \frac{1}{R_1 - \frac{w}{2}} \quad (1)$$

$$\tan \delta_o = \frac{1}{R_1 + \frac{w}{2}} \quad (2)$$

Eliminating R_1 ,

$$\begin{aligned} R_1 &= \frac{1}{2}w + \frac{l}{\tan \delta_i} \\ &= -\frac{1}{2}w + \frac{l}{\tan \delta_o} \end{aligned} \quad (3)$$

Provides the Ackerman condition:

$$\cot \delta_o - \cot \delta_i = \frac{w}{l} \quad (4)$$

Where δ_i is the steering angle of the inner wheel, and δ_o is the steering angle of the outer wheel. The inner and outer wheels are defined based on the center of rotation O . The distance between the steering axes of the steerable wheels is called the track and is denoted by w . The distance between the front and rear axles is called the wheelbase and is denoted by l . Track w and wheelbase l are considered as the kinematic width and length of a vehicle.

To find the vehicle's turning radius R , we define an equivalent bicycle model, as shown in Fig. 5.0. The radius of rotation R is perpendicular to the vehicle's velocity vector v at the mass center C . Using the geometry shown in the bicycle model, we have:

$$R^2 = a_2^2 + R_1^2 \quad (5)$$

$$\cot \delta = \frac{R_1}{l} = \frac{1}{2}(\cot \delta_i + \cot \delta_o) \quad (6)$$

Where δ is the cot-average of the inner and outer steer angles.

$$\cot \delta = \frac{\cot \delta_o + \cot \delta_i}{2} \quad (7)$$

\therefore The mass center, C of a steered locomotive will turn on a circle with radius R :

$$R = \sqrt{a_2^2 + l^2 \cot^2 \delta} \quad (8)$$

The angle δ is the equivalent steer angle of a bicycle having the same wheelbase l and radius of rotation R . The track and wheelbase are constants since they describe the skeletal framework (chassis) shown in Fig. 4.0. But the steering angles are variables since they are continually dynamic. This means that cornering toward a particular side let's say to the left-side, the steering angle of the inner wheel (δ_i), correspond vectorially to an equivalent steering angle of the outer wheel (δ_o); with these, we can evaluate for other steering parameters such as R_1 and a_2 .

Fig-5. Geometrical representation of the equivalent bicycle model for the front-wheel-steering system

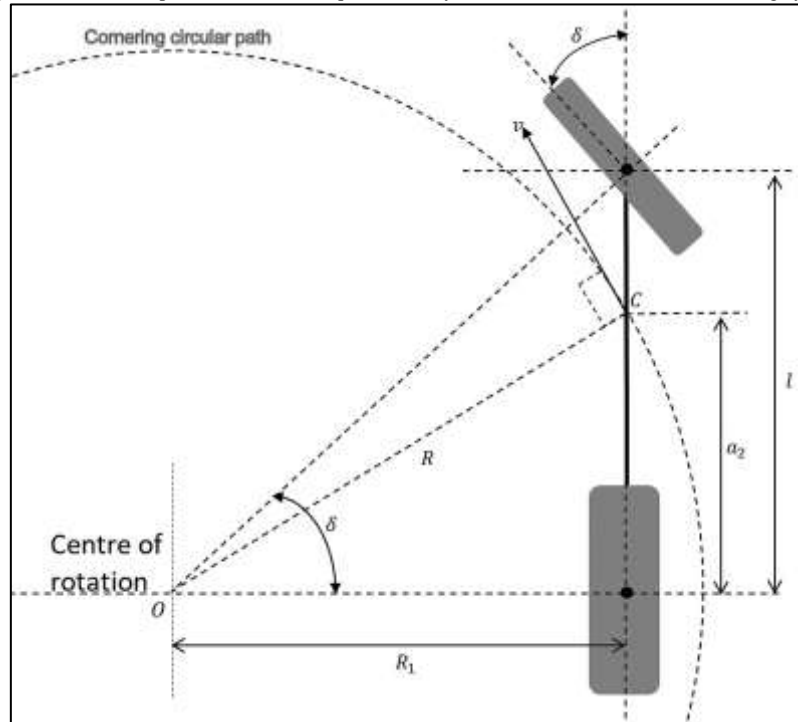

Hence w and l are the constant, while δ_i , δ_o , δ , a_2 , R_1 are variable. The inner steering wheel is positioned in the angle δ_i with the wheelbase, (l) by steering the wheel via the steering gear. The corresponding value of δ_o is measured approximately using a protractor. Hence to verify whether the measured values of this steering kinematics conforms to the Ackerman steering geometry, we use the Ackerman condition expressed as equation (4) to calculate δ_o by making δ_o subject of the formula; but it is denoted by δ_o^* to differentiate it from the measured value δ_o .

$$\delta_o^* = \cot^{-1} \left(\frac{w}{l} + \cot \delta_i \right) \quad (9)$$

From equation (7), we have:

$$\delta = \cot^{-1} \left(\frac{\cot \delta_o + \cot \delta_i}{2} \right) \quad (10)$$

And

$$R_1 = l \cot \delta_i + \frac{1}{2}w \quad (11)$$

The minimum twisting angle of any steerable wheel is zero degrees; a designer is left with the choice of deciding the maximum steering angle of his wheels based on the application at hand. The designer can achieve this by setting limits to the traversable range of the slide collar along the rail.

3.2. Implementation and Testing

Based on the design and geometrical parameters described above, a prototype of the tension-actuated steering system is constructed as shown in Fig. 6.0. The system is powered by a 12 volts DC motor through a gear-train of 9 units velocity ratio. To turn the steering in the opposite direction, the polarity of electricity supply to the driving motor is simply reversed using an H-bridge circuit.

Fig-6. Prototype of the tensional steering system

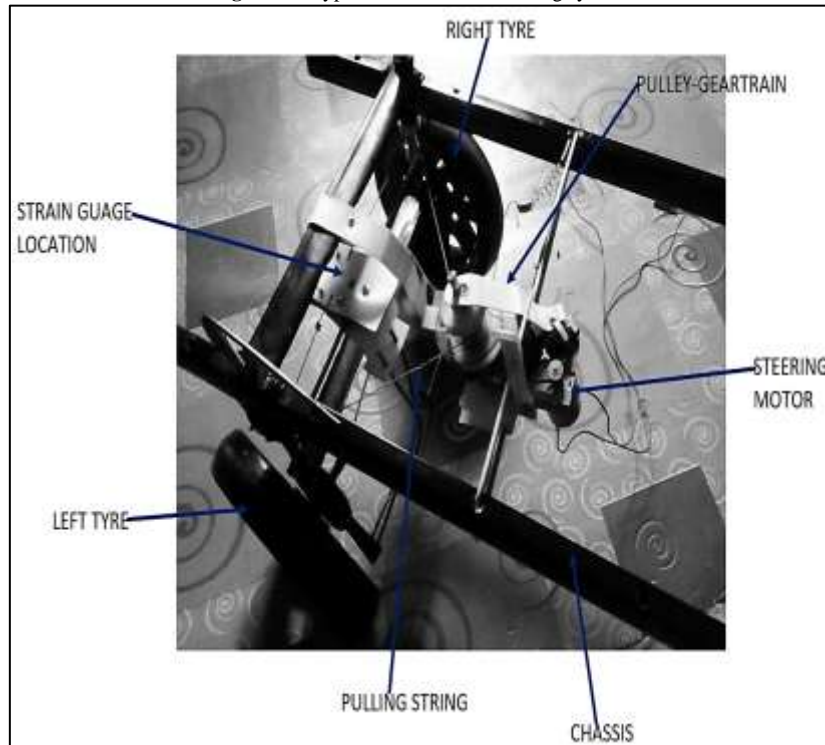

Tests were performed to determine whether the developed steering system conforms with the Ackermann steering condition in Eq.4.

4. Results and Discussion

The finished steering system was operated to sideways – towards the left- and right- hand side while the embodying robot is moving. The results of this test are discussed as follows

4.1. Result and Analysis of Steering Kinematics

According to design, the constants are: $l = 33.0\text{cm}$ and $w = 14.0\text{cm}$. The inner steering was positioned at successive inner steering angles (i.e. $\delta_i = 4.0^\circ, 8.0^\circ, 12.0^\circ, 16.0^\circ$ and 20.0°), and the corresponding outer steering angle δ_o is measured. At the same time, δ_i is substituted into Eq.9 to calculate δ_o^* – the theoretical value of δ_o . The values of δ_o and δ_o^* are correlated to determine the accuracy of the developed steering mechanism based on the Ackermann condition. For the automated computation of the steering angles, δ_o^* , the MATLAB code in Listing 1 was used. This shows the ideal kinematics of the steering design based on the Ackerman equation as plotted in Fig.7.0. The results of this steering test are tabulated as follows in Table 1.

To determine whether the alignment of the constructed steering mechanism satisfies the Ackerman's condition, the product-moment correction formula is used to evaluate the degree of relatedness between the angles δ_o and δ_o^* . The product-moment, $r = 0.996 \approx 1$. Thus, the error in the constructed steering system is: $e = 1 - 0.9962 = 0.0034$. This relationship is plotted in Fig.8.0.

Listing 1

```
%Code to compute outer steering angles%
%Generates Inner steering angle:
ang_i = 4:4:20;
%Ackermann steering equation:
ang_o = acotd ((14/33) + cotd(ang_i));
%Displays all outer steering angle:
disp(ang_o);
```

Fig-7. Graph of δ_i versus δ_o^* -- ideal variation based on Ackerman condition

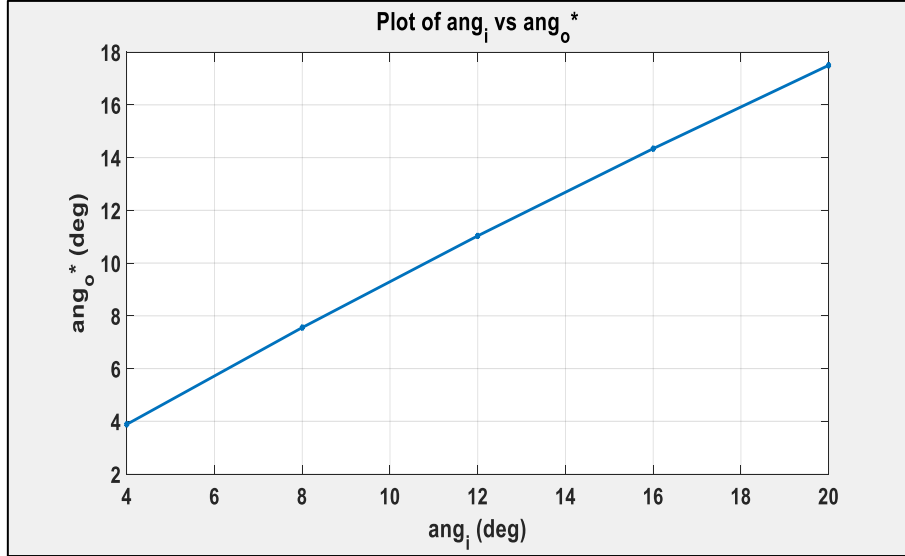

Table-1. Value of δ_i and corresponding δ_o and δ_o^*

	Independent variable	Measured variable	Calculated variable
S/N	δ_i (deg)	δ_o (deg)	δ_o^* (deg)
1	04.0000	03.5000	03.8469
2	08.0000	06.6000	07.4126
3	12.0000	11.2000	10.7331
4	16.0000	14.1300	13.8420
5	20.0000	16.5300	16.7698

4.2. Discussion

The above result represents the discrepancies that are intrinsic in the construction of the tension-actuated steering system, which is expected to function in conformity with the Ackerman condition. To this end, it can be inferred that the developed steering system performs within the acceptable margin of error and therefore, satisfies the Ackerman steering condition.

Fig-8. Correlation of δ_o (blue plot) and δ_o^* (red plot)

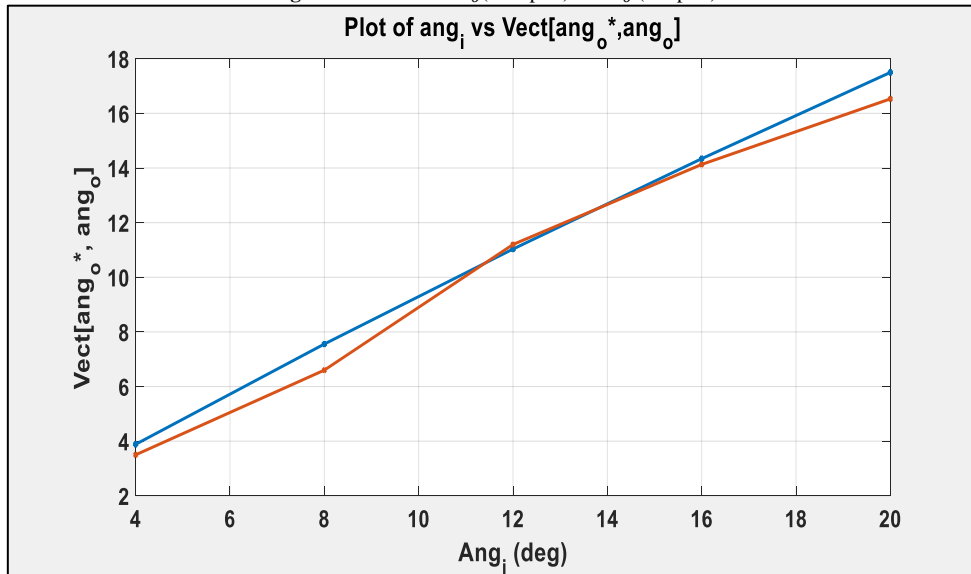

5. Conclusion

This research is largely based on the work of Reza [1]. A string-based steering system is developed. The kinematics of the system was described using the Ackermann steering geometry. The system's design was realized in physical materials. Tests and computational analyses were performed to examine the conformity of the system with the Ackerman steering condition. The developed steering system has performed within an acceptable range of error. Thus, the device and techniques proposed as a result of this work can be used to develop light-weight four-wheeled robots for low-speed maneuvering. Also, the geometrical analysis presented in this paper could be useful in the development of navigational odometers for autonomous robotic systems.

References

- [1] Reza, N. J., 2008. *Vehicle dynamics (theory and application)*, New York, manhattan college. Springer Science, Business Media.
- [2] Helmi, A. and El-Hofy, H., 2008. *Machining technology; machine tools and operation*. Baco Raton: CRC Press, Taylor and Francis Group.
- [3] Yunxiang, Y., Long, H., and Qin, Z., 2016. "Steering control strategies for a four-wheel-independent-steering bin managing robot." *IFAC-PapersOnline*, vol. 19, pp. 39-44. Available: <https://doi.org/10.1016/j.ifacol.2016.10.008>
- [4] Daniel, J., 2014. *Engineering Vibration*. 4th ed. USA: Pearson: University of Michigan.
- [5] Jin, Y. and Jorge, A., 2000. "The kinematic synthesis of steering mechanisms." *Transactions- Canadian Society for Mechanical Engineering*, vol. 24, pp. 453-476.
- [6] Crolla, D. A. and Schwanghart, H., 1992. "Vehicle dynamics-Steering, I." *Journal of Terramechanics*, vol. 29, pp. 7-17. Available: [https://doi.org/10.1016/0022-4898\(92\)90011-8](https://doi.org/10.1016/0022-4898(92)90011-8)